

General set up

- 1 Mount the fixture in the required position. The integral yoke can act as a floor stand or hanger.

Important

- When suspended off ground, always use a safety wire rated to a minimum of 11kg (25lbs) around the yoke.
- Do not position the fixture close to fog machines. The fog oil mist will be drawn in by the cooling fan and will short out important components. The warranty will be void for all fixtures returned in such a condition.

- 2 Where external control is to be used, connect a DMX lead (XLR 5-pin female) to the input socket at the rear of the fixture.
- 3 Where other fixtures are to be used in a control daisy-chain, connect a DMX lead (XLR 5-pin male) to the output socket at the rear of the fixture.

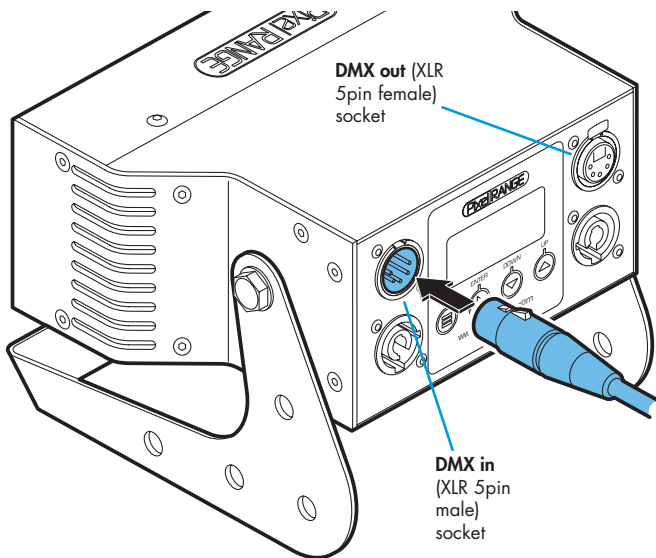

- 4 Connect power to the fixture using a Neutrik® PowerCon® connector. Insert the connector and twist it clockwise until it clicks into place.

Important

- When daisy-chaining fixtures, do not exceed a total load of 3kW in a single daisy chain (subject to supply and cabling restrictions). Maximum power requirement per fixture: 66 watts. See also the 'Start up (peak)' note on page 4.

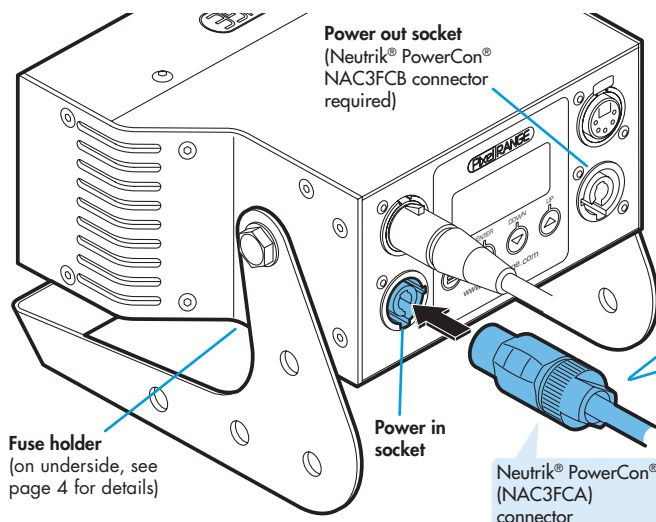

- 5 Use the control panel to access the internal menu and choose the appropriate operation mode and related settings (see over).

When suspended off ground, always use a safety wire rated to a minimum of 11kg (25lbs) around the yoke

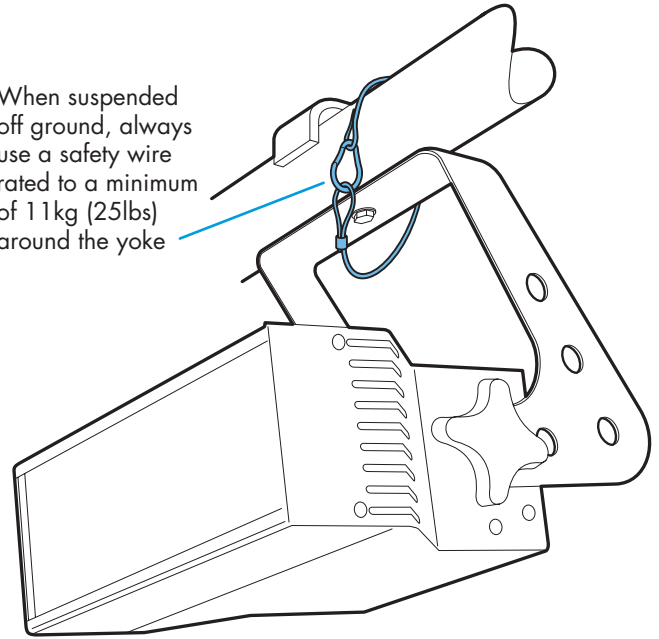

Operation modes

The PixelLine Micro Wash provides a range of operation modes. These are selected using the *Mode* section of the control menu:

- DMX** Allows RGB(A) control via DMX input. Using the *RES* (resolution) option you can determine the number of DMX channels required: either 3 or 4 channels. Internal chase effects are not available within this mode.
- MANU** Provides RGB(A) colour mixing independently of any external control. Use the internal control menu (*MAN* section) to select the required colour values.
- EF d** Allows the control of the dual internal chase effects via external DMX input.
- EF M** Allows the display of the dual internal chase effects, independently of any external control. Use the internal control menu (*PRG* section) to select the required chase effects, speeds and cross fades.
- 4+E** Provides control of RGBA mixing and selection of the dual internal chase effects via DMX input. Requires 11 DMX channels.
- 16bT** Allows RGB(A) control via DMX input, using two 8bit channels per colour. The *RES* option determines whether 6 or 8 channels are required. Internal chase effects are not available within this mode.
- DMX:T** Operates as per **DMX** mode but uses an alternative dimming curve to produce better results when viewed via television cameras.

Neutrik® PowerCon® (NAC3FCA) connector wiring

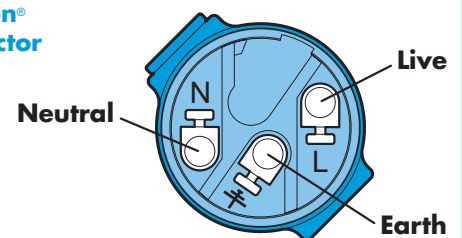

Note

- To optionally clear all previous settings: At the rear panel, press the middle two buttons (and) while the current address and mode are being displayed. The four digit display will show *FAC T* then *SET* to indicate that the fixture has been returned to its default condition.

Menu operation

General notes

- Ensure that only one DMX device in the chain is set as master (e.g. the lighting desk). This fixture is usually set to slave mode.
- This fixture is shipped with the DMX address set to 001.
- The four digit display can be set to switch off when not in use. To restore, press **MENU**. To alter this mode use: **PER5 > DISP**.

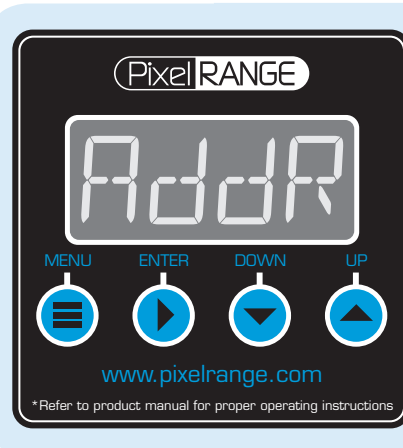

Using the menu

- When not in the menu, the four digit display scrolls the current DMX address and mode. The display's right hand decimal point (data dot) is used to indicate status (see below).
- Press **MENU** to enter the menu. The four digit display will show **Addr**.
- Use **DOWN** and **UP** to move between menu options (or to change a value within an option).
- Press **ENTER** to enter an option (or to fix a changed value within an option and return to the previous option level). *Note: If you do not press **ENTER** to fix a value, operation will revert to the previously set mode at the next power on.*
- Press **MENU** to exit from a menu option (and eventually exit the menu completely).

Chase effects

This section describes each of the 31 internal chase effects that are selectable either via the control menu (**PR05 > [1/[2] > EFEC**) or using DMX values sent from an external source. To use the internal effects, set the **MODE** option either to **EF M** (to control effects via the menu) or **EF d / 4+E** (to control effects externally via DMX). See page 4 for details about controlling effects on other fixtures via DMX without using a control desk.

DMX value	EFEC value	Chase effect description
0-7	00	Off
8-15	01	Rainbow chase forward
16-23	02	Rainbow chase reverse
24-31	03	10/90 duty cycle strobe white
32-39	04	10/90 duty cycle strobe white
40-47	05	10/90 duty cycle strobe white
48-55	06	50/50 duty cycle strobe white
56-63	07	50/50 duty cycle strobe red
64-71	08	50/50 duty cycle strobe blue
72-79	09	50/50 duty cycle strobe yellow
80-87	10	50/50 duty cycle strobe green
88-95	11	Pulse strobe white
96-103	12	Pulse strobe blue
104-111	13	Pulse strobe rainbow
112-119	14	Pulse strobe red/green/blue
120-127	15	Primary/secondary chase
128-135	16	Rainbow chase
136-143	17	Yellow/blue chase
144-151	18	Rainbow chase
152-159	19	Yellow/blue chase
160-167	20	Red/blue chase
168-175	21	Red/green chase
176-183	22	50/50 duty cycle fade red
184-191	23	50/50 duty cycle fade green
192-199	24	50/50 duty cycle fade blue
200-207	25	Static orange
208-215	26	Static yellow
216-223	27	Static light blue
224-231	28	Static purple
232-239	29	Static red
240-247	30	Static green
248-255	31	Static blue

PixelLine Micro personalities are available for a variety of controllers. For details, go to www.pixelrange.com

Channel layouts within operation modes

The table below shows how colour mixing, chase effects and master intensity controls are mapped to DMX channels for each mode. The **dm1:**, **dm1:T** and **16bT** modes do not use chase effects. In all modes, the first channel of the fixture occurs at the DMX address selected using **Addr** and successive channels for the fixture follow from there.

Note: The PER5 > RES option determines the number of channels to use in dm1:, dm1:T & 16bT modes (16bT uses twice the number of channels setup within RES).

Channel	dm1:/dm1:T (RES=3Ch)	dm1:/dm1:T (RES=4Ch)	16bT (RES=3Ch)	16bT (RES=4Ch)	4+E
1	Red+Amber	Red	Red+Amber (course)	Red (course)	Red
2	Green	Green	Red+Amber (fine)	Red (fine)	Green
3	Blue	Blue	Green (course)	Green (course)	Blue
4	Master int.*	Amber	Green (fine)	Green (fine)	Amber
5	-	Master int.*	Blue (course)	Blue (course)	[1 Effect
6	-	-	Blue (fine)	Blue (fine)	[1 Speed
7	-	-	Master int.*	Amber (course)	[1 Xfade
8	-	-	-	Amber (fine)	[2 Effect
9	-	-	-	Master int.*	[2 Speed
10	-	-	-	-	[2 Xfade
11	-	-	-	-	Master int.

* Master intensity for **dm1:**, **dm1:T** and **16bT** modes are available only when the **PER5 > MINT** option is set to **on**.

course = High channel for 16-bit, **fine** = Low channel for 16-bit

Master/slave/data indication

The right hand decimal point (data dot) of the display is used to indicate the master/slave settings and also the presence of a DMX input signal, as shown below:



Data dot ON	Master mode
Data dot FLASHING	Slave mode (DMX data input present)
Data dot OFF	Slave mode (no DMX data present)

Notes:

- Ensure that only one DMX device in the chain is set as master (e.g. the desk).
- Use **PER5 > dTRA** to change between master and slave modes.
- When set to master mode, the fixture will scroll **MASTER** in place of a DMX address (when not within the menu).
- If the display has been set to auto off (**DISP > RAFF**), the data dot will remain active but at a lower brightness.

Menu contents

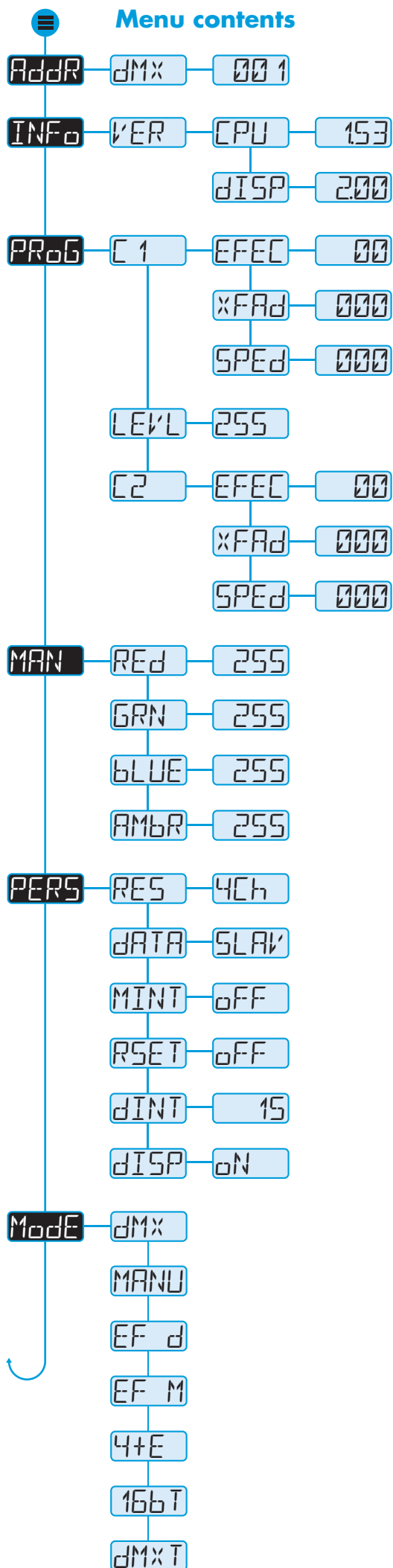

Sets the base DMX address from which the control channels will begin.

Shows the installed revision of the main fixture firmware. This is for information purposes only, no changes are possible within this option.

Shows the installed revision of the software used to control the four digit display panel. This is for information purposes only, no changes are possible within this option.

Selects the primary internal chase effect. See *Chase effects* for descriptions. Select *ModE > EF M* to show the selected chase.

Selects the cross fade speed between the steps of the selected *C1* chase effect.

Selects the speed of the selected *C1* chase effect.

Selects the master intensity level of chase effects *C1* and *C2*.

Selects the secondary internal chase effect. See *Chase effects* for descriptions. Select *ModE > EF M* to show the selected chase.

Selects the cross fade speed between the steps of the selected *C2* chase effect.

Selects the speed of the selected *C2* chase effect.

Sets the red intensity. Select *ModE > MANU* (manual) to show the result.

Sets the green intensity. Select *ModE > MANU* (manual) to show the result.

Sets the blue intensity. Select *ModE > MANU* (manual) to show the result.

Sets the amber intensity. Select *ModE > MANU* (manual) to show the result.

(Affects *dM* & *16bT* modes only) Determines how colours are assigned to DMX channels. Options are *4Ch* and *3Ch* (red & amber combined).

Determines whether this fixture will act as a master controlling others. When controlled by DMX input, this fixture must be set to *SLAV*.

Affects *dM* & *16bT* modes only. When set *ON* this enables the master intensity channel for *dM* & *16bT* modes.

When set *ON*, this option scrolls through the primary colours at power on to demonstrate correct operation.

Determines the intensity of the four digit control panel display. Values range from 0 (dimpest) to 15 (brightest).

When set to *RAFF*, the control panel display will blank out shortly after the menu is exited. The master/slave/DMX signal indication will remain active.

8bit RGB(A) control using the number of DMX channels determined by *PERS > RES*. *PERS > MINT* set to *ON* provides a master intensity. No chase effects are selectable.

Displays the resulting RGB levels that are set via the *MAN* section of the internal menu. When set as master, these levels are also output via DMX for the control of other fixtures.

Ch1 to 3: *C1* Effect, Speed & Xfade, Ch4 to 6: *C2* Effect, Speed & Xfade, Ch7: Master intensity.

Displays the chase effect(s) determined within the *PRG* section. When set as master, these levels are also output via DMX for the control of other fixtures.

DMX Ch1 to 4: RGBA, Ch5 to 7: *C1* Effect, Speed & Xfade, Ch8 to 10: *C2* Effect, Speed & Xfade, Ch11: Master intensity.

16bit RGB(A) control using 2x the number of DMX channels determined by *PERS > RES*. *PERS > MINT* set to *ON* provides a master intensity. No chase effects are selectable.

Operates as per *dM* mode but uses an alternative dimming curve to produce better results when viewed via television cameras.

Using master mode to drive other units

This unit can control any number of other Pixel Range fixtures via DMX links, without the need for a control desk.

- 1 Set this unit as **master** (*PER5 > DATA > MAST*) and ensure all others are set to **slave** (*PER5 > DATA > SLAVE*). Connect all fixtures via DMX daisy-chain.
- 2 Set slaves to *ModE > dM::* or *dM::T*. Set the master to either:
 - *ModE > EF M* and use *PRoG* to choose **effects**, or
 - *ModE > MANU* and use *MAN* to choose **colour mix**.
- 3 Use *AddrP > dM::* to set slave addresses (*the master unit's DMX address is ignored*):
 - **Effects:** 18 cells are output in groups of 3 DMX channels to give RGB values per cell (54 channels in total). Set the address of each slave fixture according to which of the 18 cells you want them to appear within, or to begin with (for multi-cell fixtures): (*ADD 1* for cell 1, *ADD 4* for cell 2, ... *ADD 2* for cell 18). Set RGBA slave fixtures to 3 channel mode (using *PER5 > RES > 3Ch*).
 - **Colour mix:** Set slaves to any addresses on 4 channel boundaries, e.g. *ADD 1*, *ADD 5*, *ADD 9*, ... *ADD 48*.

Troubleshooting

Fixture remains at blackout when illumination expected

- If the display panel is not showing any indication, even after a button press, check the input power and fuse.
- If live DMX is connected, the right hand decimal point on the display should flash - if not, check the DMX cable and the desk output.
- Check that the selected *ModE* matches the desk personality being used.
- The master intensity channel for the current mode may be set at zero. For *dM::* or *16bT* modes, check the setting of *PER5 > MINT*.
- Ensure that only one DMX device is set as master.
- Standalone chase effects: Effects programmed using *PRoG > C 1* and *C 2* but the fixture is not in *ModE > EF M* mode. Check also that *PRoG > LEVL* is not set at zero.
- Standalone RGB mixing: Colour values set within *MAN* section but the fixture is not in *ModE > MANU* mode.

Fuse access

The single fuse is located on the underside panel of the fixture.

To remove the fuse

Using a flatblade screwdriver, push down the fuse cap and then twist it anti-clockwise until it disengages from the holder.

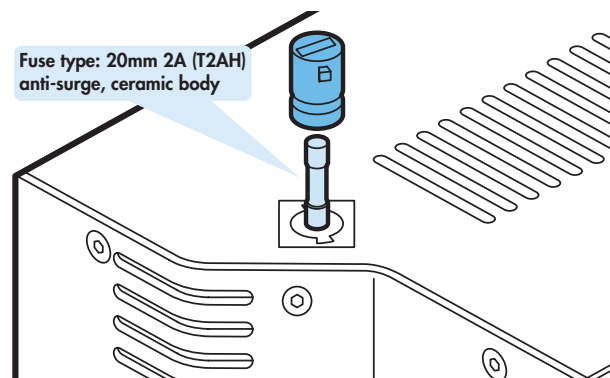

Documentation by Corporate Text & Design (www.ctxd.com)
Release 1.53b

Specifications

Dimensions

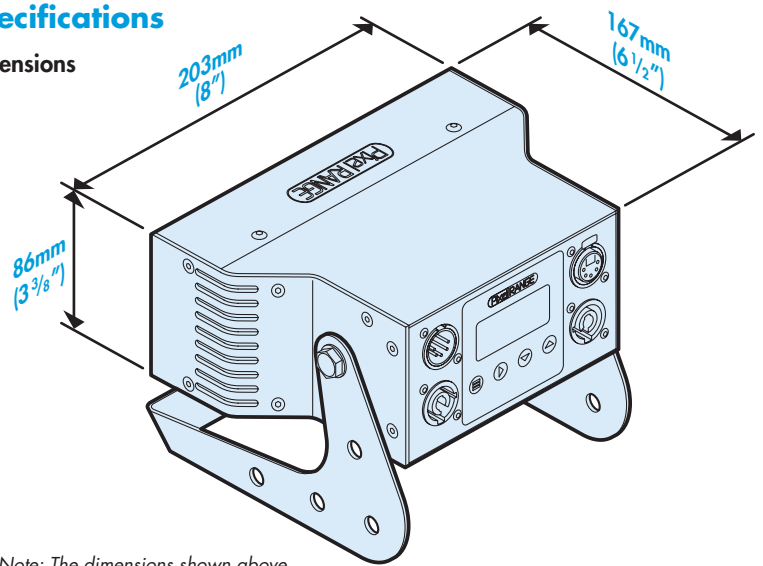

Note: The dimensions shown above relate to the main fixture body. The yoke knob extends 10mm (3/8") beyond the stated width of the fixture.

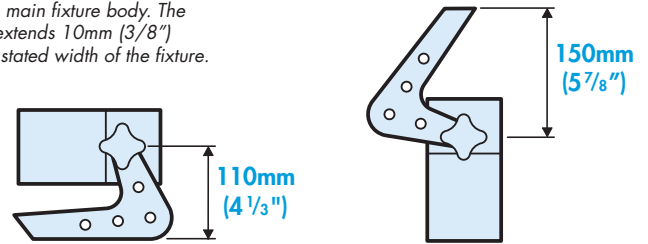

Weight

Fixture and yoke: 2.1Kg (4.6lbs)

Power

Input voltage:	90 to 264V AC, 47 to 63Hz autosensing	
Earth leakage	0.12mA	
Connectors:	Neutrik® PowerCon® (see first page for details)	
Power requirements:	@ 230V/50Hz	@ 115V/60Hz
Standby	2 watts	2 watts
Maximum (const.)	66 watts	66 watts
Start up (peak*)	<40 amps	<20 amps

* The peak value occurs only at first power up and lasts only for a period measured in microseconds. Adjustments may need to be made to supply circuit breakers when multiple fixtures are daisy-chained, causing them all to draw the peak simultaneously.

Approvals



Miscellaneous

Enclosure rating: IP20 (not protected against moisture ingress)
Control input: USITT DMX512 (input connector pin out below)

