

General set up

- 1 Mount the fixture in the required position. Brackets and bolts are supplied to allow you to mount the unit in a variety of locations.
- 2 Connect a DMX control feed (where necessary) and power to the unit. PixelArc fixtures are supplied in two variants: H1 (outdoor) and H2 (entertainment).

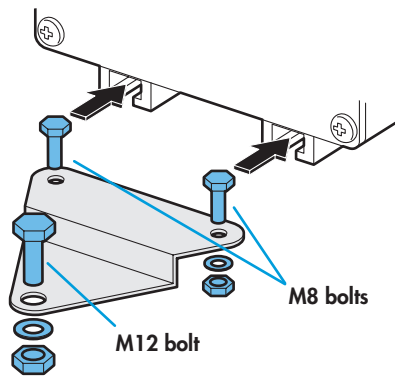

Note: Connections should be made only by a qualified electrician.

H1 (outdoor) connections

- **DMX:** Remove the end panel next to the conduit fittings. Feed the DMX-in cable (and DMX-out cable, if necessary) through the conduit fitting(s) on the front panel. Attach the DMX leads to the upper connector block, as shown below.

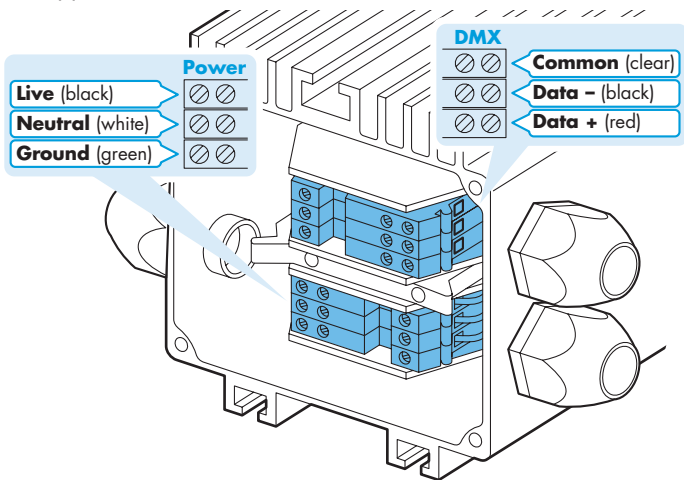

- **Power:** Feed the power-in cable (12awg conductors) through one of the two conduit fittings on the rear panel. If you require a power-out cable, feed it through the other conduit fitting on the rear panel. Attach the power leads securely to the lower connector block as shown above.

Note: Ensure that the re-fitted end panel and all conduit cable fittings have a watertight seal.

H2 (entertainment) connections

- **DMX:** Connect a DMX lead (XLR 5-pin female) to the input socket on the end panel of the fixture.
- **Power:** Attach the supplied bare-wire power cord to a suitably rated power connector.

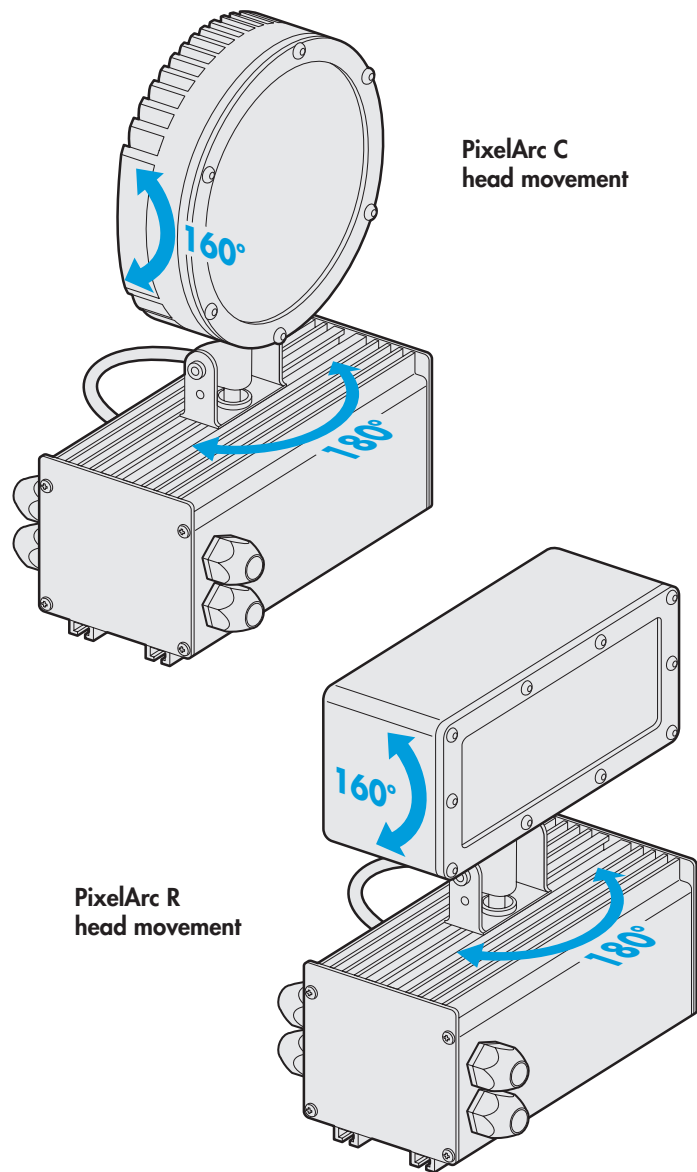
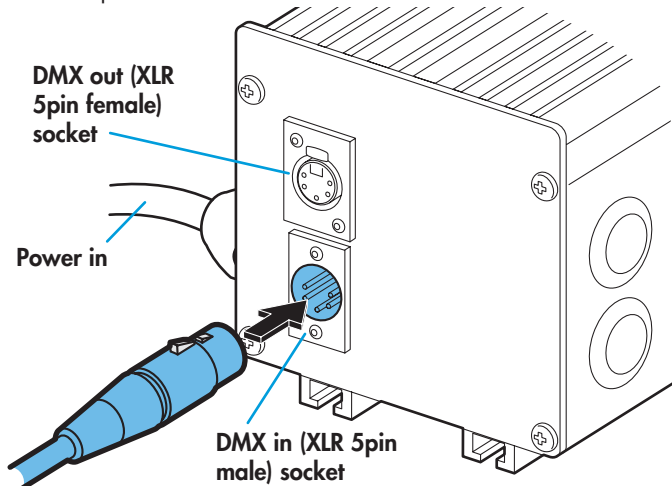

Operation modes

The PixelArc fixtures provide a range of operation modes. These are selected using the **MODE** section of the control menu:

- **DMX:** Allows RGBA control via DMX input. Using the **RES** (resolution) option you can determine the number of DMX channels required: either 3 or 4 channels. In 3 channel mode, the red and amber channels are combined, whereas in 4 channel mode, the red and amber channels are controlled separately. Internal chase effects are not available within this mode.
- **MANU:** Provides RGBA color mixing independently of any external control. Use the internal control menu (**MAN** section) to select the required color values.
- **EF M:** Allows the display of the dual internal chase effects, independently of any external control. Use the internal control menu (**PRG** section) to select the required chase effects, speeds and cross fades.
- **4+E:** Provides control of RGBA mixing and selection of the dual internal chase effects via DMX input. Requires 11 DMX channels.

PixelArc personalities are available for a variety of controllers. Please see www.pixelrange.com for details.

Menu operation

General notes

- Ensure that only one DMX device in the chain is set as master (e.g. the lighting desk). This fixture is usually set to slave mode.
- This fixture is shipped with the DMX address set to 001.
- The four digit display can be set to switch off when not in use. To restore, press **MENU**. To alter this mode use: **PER5 > DISP**.

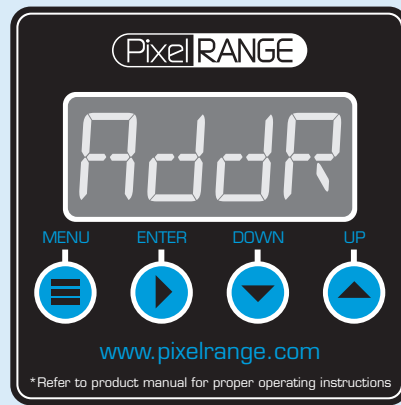

Using the menu

- When not in the menu, the four digit display shows the current DMX address e.g. **0001**. Some of the display's decimal points are used to indicate status (see below).
- Press **MENU** to enter the menu. The four digit display will show **Addr**.
- Use **DOWN** and **UP** to move between menu options (or to change a value within an option).
- Press **ENTER** to enter an option (or to fix a changed value within an option and return to the previous option level). *Note: If you do not press **ENTER** to fix a value, operation will revert to the previously set mode at the next power on.*
- Press **MENU** to exit from a menu option (and eventually exit the menu completely).

Chase effects

This section describes each of the 31 internal chase effects that are selectable either via the control menu (**PER5 > C1/E2 > EFEC**) or using DMX values sent from an external source. To use the internal effects, set the **MODE** option either to **EF M** (to control effects via the menu) or **4+E** (to control effects externally via DMX). See page 4 for details about controlling effects on other fixtures via DMX without using a control desk.

DMX value	EFEC value	Chase effect description
0-7	00	Off
8-15	01	Rainbow chase forward
16-23	02	Rainbow chase reverse
24-31	03	10/90 duty cycle strobe white
32-39	04	10/90 duty cycle strobe white
40-47	05	10/90 duty cycle strobe white
48-55	06	50/50 duty cycle strobe white
56-63	07	50/50 duty cycle strobe red
64-71	08	50/50 duty cycle strobe blue
72-79	09	50/50 duty cycle strobe yellow
80-87	10	50/50 duty cycle strobe green
88-95	11	Pulse strobe white
96-103	12	Pulse strobe blue
104-111	13	Pulse strobe rainbow
112-119	14	Pulse strobe red/green/blue
120-127	15	Primary/secondary chase
128-135	16	Rainbow chase
136-143	17	Yellow/blue chase
144-151	18	Rainbow chase
152-159	19	Yellow/blue chase
160-167	20	Red/blue chase
168-175	21	Red/green chase
176-183	22	50/50 duty cycle fade red
184-191	23	50/50 duty cycle fade green
192-199	24	50/50 duty cycle fade blue
200-207	25	Static orange
208-215	26	Static yellow
216-223	27	Static light blue
224-231	28	Static purple
232-239	29	Static red
240-247	30	Static green
248-255	31	Static blue

Channel layouts within operation modes

The table below shows how color mixing, chase effects and master intensity controls are mapped to DMX channels for each mode. Mode **dm1** does not use chase effects. In all modes, the first channel of the fixture occurs at the DMX address selected using **Addr** and successive channels for the fixture follow from there.

*Note: The **PER5 > RES** option determines the number of channels required within **dm1** mode. There is a **16bT** option which does not operate, do not select this option.*

Channel	dm1 (RES=3Ch)	dm1 (RES=4Ch)	4+E
1	Red	Red	Red
2	Green	Green	Green
3	Blue	Blue	Blue
4	Master intensity*	Amber	Amber
5	-	Master intensity*	C1 Effect
6	-	-	C1 Speed
7	-	-	C1 Xfade
8	-	-	C2 Effect
9	-	-	C2 Speed
10	-	-	C2 Xfade
11	-	-	Master intensity

* Master intensity for **dm1** mode is available only when the **PER5 > MINT** option is set to **on**.

Display indications

Three of the display's decimal points are used to indicate the master/slave settings and also the presence of a DMX input signal, as shown below:



Master mode

On when the fixture is set within master mode. Use **PER5 > dATA** to change.

Slave mode

On when the fixture is set within slave mode. Use **PER5 > dATA** to change.

DMX input

Flashes when a valid DMX input signal is detected.

Note: Ensure that only one DMX device in the chain is set as master (e.g. the lighting desk). This fixture is usually set to slave mode.

Menu contents

<div style="text-align: center; border: 1px solid black; padding: 2px; width: 30px; margin: 0 auto;">☰</div> <div style="margin-top: 10px;"> <div style="display: flex; align-items: center; margin-bottom: 5px;"> <div style="border: 1px solid black; padding: 2px; width: 60px; text-align: center;">Addr</div> <div style="margin: 0 10px;">DMX</div> <div style="border: 1px solid black; padding: 2px; width: 60px; text-align: center;">001</div> </div> </div>	<p>Sets the base DMX address from which the control channels will begin.</p>
<div style="margin-top: 10px;"> <div style="display: flex; align-items: center; margin-bottom: 5px;"> <div style="border: 1px solid black; padding: 2px; width: 60px; text-align: center;">Info</div> <div style="margin: 0 10px;">VER</div> <div style="border: 1px solid black; padding: 2px; width: 60px; text-align: center;">CPU</div> <div style="margin: 0 10px;">V</div> <div style="border: 1px solid black; padding: 2px; width: 60px; text-align: center;">101</div> </div> <div style="display: flex; align-items: center; margin-bottom: 5px;"> <div style="margin: 0 10px;">DISP</div> <div style="border: 1px solid black; padding: 2px; width: 60px; text-align: center;">200</div> </div> </div>	<p>Shows the main processor software revision. No changes are possible within this option.</p> <p>Shows the display controller software revision. No changes are possible within this option.</p>
<div style="margin-top: 10px;"> <div style="display: flex; align-items: center; margin-bottom: 5px;"> <div style="border: 1px solid black; padding: 2px; width: 60px; text-align: center;">Prog</div> <div style="margin: 0 10px;">C1</div> <div style="border: 1px solid black; padding: 2px; width: 60px; text-align: center;">EFEC</div> <div style="border: 1px solid black; padding: 2px; width: 60px; text-align: center;">00</div> </div> <div style="display: flex; align-items: center; margin-bottom: 5px;"> <div style="margin: 0 10px;">XFAD</div> <div style="border: 1px solid black; padding: 2px; width: 60px; text-align: center;">000</div> </div> <div style="display: flex; align-items: center; margin-bottom: 5px;"> <div style="margin: 0 10px;">SPEED</div> <div style="border: 1px solid black; padding: 2px; width: 60px; text-align: center;">000</div> </div> <div style="display: flex; align-items: center; margin-bottom: 5px;"> <div style="margin: 0 10px;">LEVL</div> <div style="border: 1px solid black; padding: 2px; width: 60px; text-align: center;">255</div> </div> <div style="display: flex; align-items: center; margin-bottom: 5px;"> <div style="margin: 0 10px;">C2</div> <div style="border: 1px solid black; padding: 2px; width: 60px; text-align: center;">EFEC</div> <div style="border: 1px solid black; padding: 2px; width: 60px; text-align: center;">00</div> </div> <div style="display: flex; align-items: center; margin-bottom: 5px;"> <div style="margin: 0 10px;">XFAD</div> <div style="border: 1px solid black; padding: 2px; width: 60px; text-align: center;">000</div> </div> <div style="display: flex; align-items: center; margin-bottom: 5px;"> <div style="margin: 0 10px;">SPEED</div> <div style="border: 1px solid black; padding: 2px; width: 60px; text-align: center;">000</div> </div> </div>	<p>Selects the primary internal chase effect. See <i>Chase effects</i> for descriptions. Select <i>Mode</i> > <i>EF M</i> to show the selected chase.</p> <p>Selects the cross fade speed between the steps of the selected C1 chase effect.</p> <p>Selects the speed of the selected C1 chase effect.</p> <p>Selects the master intensity level of chase effects C1 and C2.</p> <p>Selects the secondary internal chase effect. See <i>Chase effects</i> for descriptions. Select <i>Mode</i> > <i>EF M</i> to show the selected chase.</p> <p>Selects the cross fade speed between the steps of the selected C2 chase effect.</p> <p>Selects the speed of the selected C2 chase effect.</p>
<div style="margin-top: 10px;"> <div style="display: flex; align-items: center; margin-bottom: 5px;"> <div style="border: 1px solid black; padding: 2px; width: 60px; text-align: center;">MAN</div> <div style="margin: 0 10px;">RED</div> <div style="border: 1px solid black; padding: 2px; width: 60px; text-align: center;">255</div> </div> <div style="display: flex; align-items: center; margin-bottom: 5px;"> <div style="margin: 0 10px;">AMBR</div> <div style="border: 1px solid black; padding: 2px; width: 60px; text-align: center;">255</div> </div> <div style="display: flex; align-items: center; margin-bottom: 5px;"> <div style="margin: 0 10px;">BLUE</div> <div style="border: 1px solid black; padding: 2px; width: 60px; text-align: center;">255</div> </div> <div style="display: flex; align-items: center; margin-bottom: 5px;"> <div style="margin: 0 10px;">GRN</div> <div style="border: 1px solid black; padding: 2px; width: 60px; text-align: center;">255</div> </div> </div>	<p>Sets the red intensity. Select <i>Mode</i> > <i>MANU</i> (manual) to show the result.</p> <p>Sets the amber intensity. Select <i>Mode</i> > <i>MANU</i> (manual) to show the result.</p> <p>Sets the blue intensity. Select <i>Mode</i> > <i>MANU</i> (manual) to show the result.</p> <p>Sets the green intensity. Select <i>Mode</i> > <i>MANU</i> (manual) to show the result.</p>
<div style="margin-top: 10px;"> <div style="display: flex; align-items: center; margin-bottom: 5px;"> <div style="border: 1px solid black; padding: 2px; width: 60px; text-align: center;">PERS</div> <div style="margin: 0 10px;">RES</div> <div style="border: 1px solid black; padding: 2px; width: 60px; text-align: center;">4Ch</div> </div> <div style="display: flex; align-items: center; margin-bottom: 5px;"> <div style="margin: 0 10px;">DATA</div> <div style="border: 1px solid black; padding: 2px; width: 60px; text-align: center;">SLAV</div> </div> <div style="display: flex; align-items: center; margin-bottom: 5px;"> <div style="margin: 0 10px;">MINT</div> <div style="border: 1px solid black; padding: 2px; width: 60px; text-align: center;">OFF</div> </div> <div style="display: flex; align-items: center; margin-bottom: 5px;"> <div style="margin: 0 10px;">DINT</div> <div style="border: 1px solid black; padding: 2px; width: 60px; text-align: center;">15</div> </div> <div style="display: flex; align-items: center; margin-bottom: 5px;"> <div style="margin: 0 10px;">DISP</div> <div style="border: 1px solid black; padding: 2px; width: 60px; text-align: center;">ON</div> </div> </div>	<p>(Affects <i>DM1</i> mode only) Determines how DMX channels are assigned to colors. Options are 3Ch (red & amber combined), 4Ch and 16bT (do not use).</p> <p>Determines whether this fixture will act as a master controlling others. When controlled by DMX input, this fixture must be set to <i>SLAV</i>.</p> <p>Affects <i>DM1</i> mode only. When set <i>ON</i> this enables the master intensity channel for <i>DM1</i> mode.</p> <p>Determines the intensity of the four digit control panel display. Values range from 0 (dimtest) to 15 (brightest).</p> <p>When set to <i>OFF</i>, the control panel display will blank out shortly after the menu is exited. The DMX signal indications will remain active.</p>
<div style="margin-top: 10px;"> <div style="display: flex; align-items: center; margin-bottom: 5px;"> <div style="border: 1px solid black; padding: 2px; width: 60px; text-align: center;">Mode</div> <div style="margin: 0 10px;">DMX</div> </div> <div style="display: flex; align-items: center; margin-bottom: 5px;"> <div style="margin: 0 10px;">MANU</div> </div> <div style="display: flex; align-items: center; margin-bottom: 5px;"> <div style="margin: 0 10px;">EF M</div> </div> <div style="display: flex; align-items: center; margin-bottom: 5px;"> <div style="margin: 0 10px;">4+E</div> </div> </div>	<p>RGB control using three DMX channels. <i>MINT</i> set to <i>ON</i> provides a master intensity. No chase effects are selectable.</p> <p>Displays the resulting RGB levels that are set via the <i>MANU</i> section of the internal menu. External DMX control is not possible in this mode.</p> <p>Displays the chase effect(s) determined within the <i>PRoG</i> section. External DMX control is not possible in this mode.</p> <p>DMX Ch1 to 3: RGB, Ch4 to 6: C1 Effect, Speed & Xfade, Ch7 to 9: C2 Effect, Speed & Xfade, Ch10: Master intensity.</p>

Using master mode to drive other units

This unit can control any number of other Pixel Range fixtures via DMX links, without the need for a control desk.

- 1 Set this unit as **master** (*PER5 > DATA > MAST*) and ensure all others are set to **slave** (*PER5 > DATA > SLAV*). Connect all fixtures via DMX daisy-chain.
- 2 Set each slave to *ModE > dM*. Set the master to either:
 - *ModE > EF M* and use *PRoG* to choose **effects**, or
 - *ModE > MANU* and use *MAN* to choose **colour mix**.
- 3 Use *AddrP > dM* to set slave addresses (*the master unit's DMX address is ignored*):
 - **Effects:** 18 cells are output in groups of 3 DMX channels to give RGB values per cell (54 channels in total). Set the address of each slave fixture according to which of the 18 cells you want them to appear within, or to begin with (for multi-cell fixtures): (*ADD 1* for cell 1, *ADD 4* for cell 2, ... *ADD 52* for cell 18).
 - **Colour mix:** Set slaves to any addresses on 3 channel boundaries, e.g. *ADD 1, ADD 4, ADD 7, ... ADD 52*.

Troubleshooting

Fixture remains at blackout when illumination expected

- The display panel (or at least one of its decimal points) should be lit - if not, check the input power and fuse.
- If live DMX is connected, the right hand decimal point on the display should flash - if not, check the DMX cable and the desk output.
- Check that the selected *ModE* matches the desk personality being used.
- The master intensity channel for the current mode may be set at zero. For *dM* mode, check the setting of *PER5 > MINT*.
- Ensure that only one DMX device is set as master.
- Standalone chase effects: Effects programmed using *PRoG > C 1* and *C 2* but the fixture is not in *ModE > EF M* mode. Check also that *ModE > PRoG > LEVL* is not set at zero.
- Standalone RGB mixing: Color values set within *MAN* section but the fixture is not in *ModE > MANU* mode.

Fuse access

The main fuse is located within the casing of the fixture.

To remove the fuse

Remove the end panel next to the conduit fittings. Locate the fuse holder situated between the two connector blocks. Grip the lever on the left side of the holder and pull it open to reveal the fuse.

Fuse type: 5x20mm
2A GMC-2 (glass)

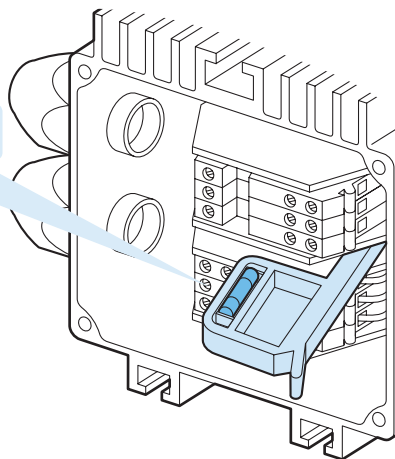

Documentation by Corporate Text & Design (www.ctxd.com)

Release 1.0e

Specifications

Dimensions

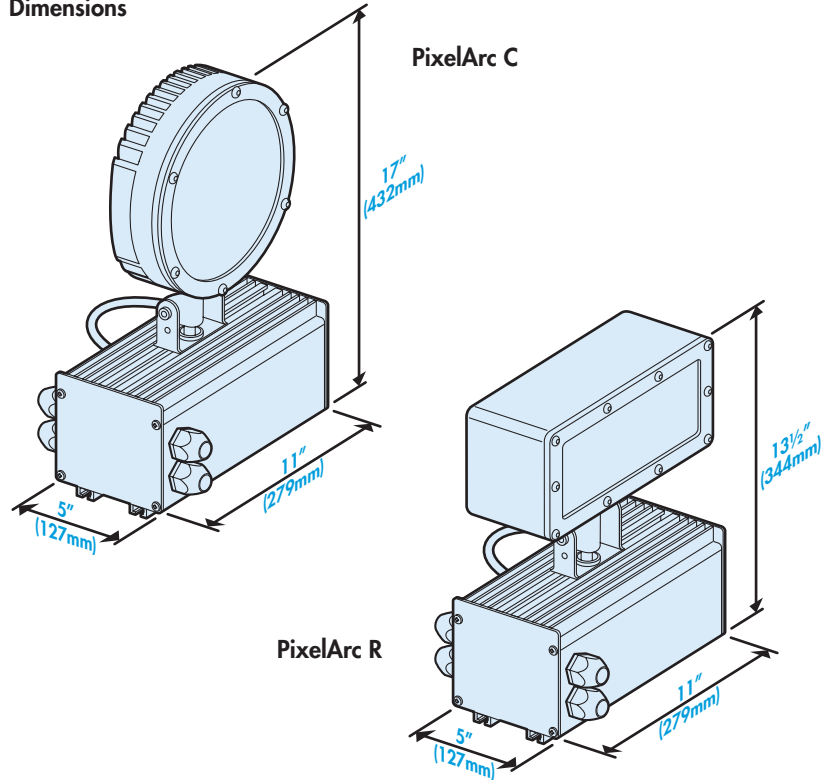

Weight

Complete fixture:

PixelArc C

13.5lbs (6.12Kg)

PixelArc R

12.5lbs (5.67Kg)

Power

Input voltage:

90 to 264V AC, 47 to 63Hz autosensing

Earth leakage:

0.54mA

0.54mA

Power requirements:

PixelArc C

PixelArc R

@230V @115V
50Hz 60Hz

@230V @115V
50Hz 60Hz

Standby

1.5W 1.5W

2W 2W

Maximum (const.)

127W 127W

66W 66W

Start up (peak)*

>64A >32A

>64A >32A

* The peak value occurs only at first power up and lasts only for a period measured in micro-seconds.

Approvals

H1 variant: UL #305745

H2 variant: None

Miscellaneous

Enclosure rating:

H1 variant: IP65

H2 variant: IP54

Control input (H2):

USITT DMX512 (input connector pin out below)

